

جانمایی شاسی گیربکس و نشیمن کوپلینگ ها جهت نصب به همین صورت باشد
ولی جنس ، سختی و شکل دنده ها از رایج ترین ها باشد

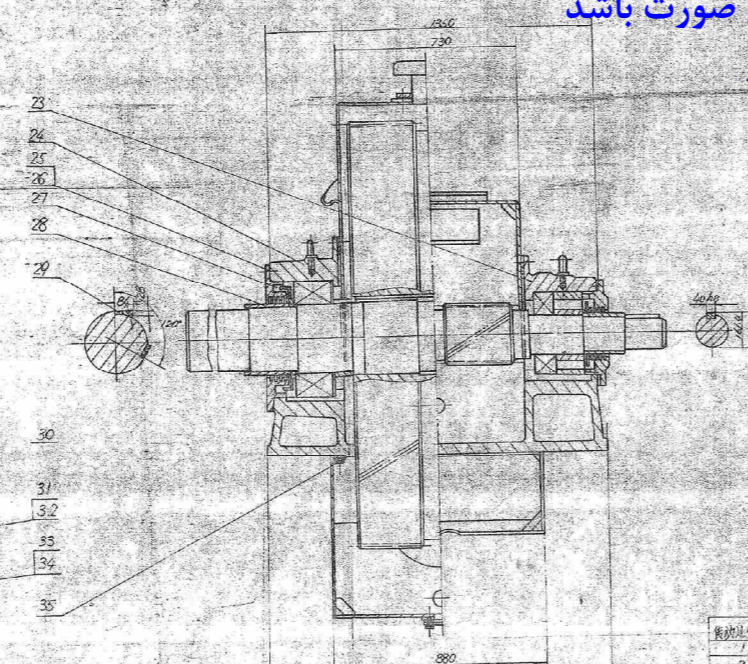
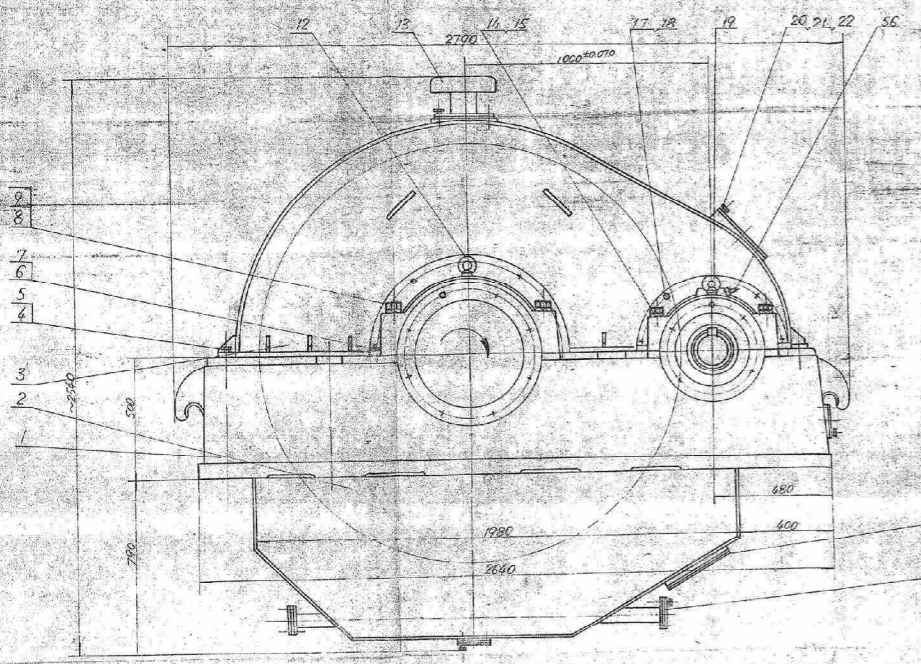

前视图
半轴视图
中心距 A=100
装配代号 5
材料 ZD100B-5-2

零件表

零件代号	数量	规格	材料	重量
1	1	ZD100B-5-2	ZD100B-5-2	1000
2	2	6.2711100.02.2002-2	6.2711100.02.2002-2	100
3	2	6.2711100.02.2002-2	6.2711100.02.2002-2	100
4	2	6.2711100.02.2002-2	6.2711100.02.2002-2	100
5	2	6.2711100.02.2002-2	6.2711100.02.2002-2	100
6	2	6.2711100.02.2002-2	6.2711100.02.2002-2	100

装配型式

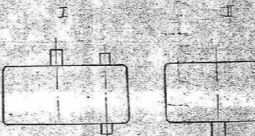

技术要求

1. 所有的结合零件，规定的零件号(2, 3, 4)与列出的规格，应与与原件配合校正进行。
2. 所有零件的未加工表面应涂防锈油，涂油后应涂防锈漆，漆体应各零件的未加工表面涂防锈油，涂油后应涂防锈漆。
3. 装配时各零件的未加工表面，应涂防锈油，涂油后应涂防锈漆。
4. 装配时各零件的未加工表面，应涂防锈油，涂油后应涂防锈漆。
5. 装配时各零件的未加工表面，应涂防锈油，涂油后应涂防锈漆。
6. 装配时各零件的未加工表面，应涂防锈油，涂油后应涂防锈漆。
7. 装配时各零件的未加工表面，应涂防锈油，涂油后应涂防锈漆。
8. 装配时各零件的未加工表面，应涂防锈油，涂油后应涂防锈漆。
9. 装配时各零件的未加工表面，应涂防锈油，涂油后应涂防锈漆。
10. 装配时各零件的未加工表面，应涂防锈油，涂油后应涂防锈漆。
11. 装配时各零件的未加工表面，应涂防锈油，涂油后应涂防锈漆。
12. 装配时各零件的未加工表面，应涂防锈油，涂油后应涂防锈漆。
13. 装配时各零件的未加工表面，应涂防锈油，涂油后应涂防锈漆。
14. 装配时各零件的未加工表面，应涂防锈油，涂油后应涂防锈漆。
15. 装配时各零件的未加工表面，应涂防锈油，涂油后应涂防锈漆。
16. 装配时各零件的未加工表面，应涂防锈油，涂油后应涂防锈漆。
17. 装配时各零件的未加工表面，应涂防锈油，涂油后应涂防锈漆。
18. 装配时各零件的未加工表面，应涂防锈油，涂油后应涂防锈漆。
19. 装配时各零件的未加工表面，应涂防锈油，涂油后应涂防锈漆。
20. 装配时各零件的未加工表面，应涂防锈油，涂油后应涂防锈漆。
21. 装配时各零件的未加工表面，应涂防锈油，涂油后应涂防锈漆。
22. 装配时各零件的未加工表面，应涂防锈油，涂油后应涂防锈漆。
23. 装配时各零件的未加工表面，应涂防锈油，涂油后应涂防锈漆。
24. 装配时各零件的未加工表面，应涂防锈油，涂油后应涂防锈漆。
25. 装配时各零件的未加工表面，应涂防锈油，涂油后应涂防锈漆。
26. 装配时各零件的未加工表面，应涂防锈油，涂油后应涂防锈漆。
27. 装配时各零件的未加工表面，应涂防锈油，涂油后应涂防锈漆。
28. 装配时各零件的未加工表面，应涂防锈油，涂油后应涂防锈漆。
29. 装配时各零件的未加工表面，应涂防锈油，涂油后应涂防锈漆。
30. 装配时各零件的未加工表面，应涂防锈油，涂油后应涂防锈漆。
31. 装配时各零件的未加工表面，应涂防锈油，涂油后应涂防锈漆。
32. 装配时各零件的未加工表面，应涂防锈油，涂油后应涂防锈漆。
33. 装配时各零件的未加工表面，应涂防锈油，涂油后应涂防锈漆。
34. 装配时各零件的未加工表面，应涂防锈油，涂油后应涂防锈漆。
35. 装配时各零件的未加工表面，应涂防锈油，涂油后应涂防锈漆。
36. 装配时各零件的未加工表面，应涂防锈油，涂油后应涂防锈漆。
37. 装配时各零件的未加工表面，应涂防锈油，涂油后应涂防锈漆。
38. 装配时各零件的未加工表面，应涂防锈油，涂油后应涂防锈漆。
39. 装配时各零件的未加工表面，应涂防锈油，涂油后应涂防锈漆。
40. 装配时各零件的未加工表面，应涂防锈油，涂油后应涂防锈漆。
41. 装配时各零件的未加工表面，应涂防锈油，涂油后应涂防锈漆。
42. 装配时各零件的未加工表面，应涂防锈油，涂油后应涂防锈漆。
43. 装配时各零件的未加工表面，应涂防锈油，涂油后应涂防锈漆。
44. 装配时各零件的未加工表面，应涂防锈油，涂油后应涂防锈漆。
45. 装配时各零件的未加工表面，应涂防锈油，涂油后应涂防锈漆。
46. 装配时各零件的未加工表面，应涂防锈油，涂油后应涂防锈漆。
47. 装配时各零件的未加工表面，应涂防锈油，涂油后应涂防锈漆。
48. 装配时各零件的未加工表面，应涂防锈油，涂油后应涂防锈漆。
49. 装配时各零件的未加工表面，应涂防锈油，涂油后应涂防锈漆。
50. 装配时各零件的未加工表面，应涂防锈油，涂油后应涂防锈漆。
51. 装配时各零件的未加工表面，应涂防锈油，涂油后应涂防锈漆。
52. 装配时各零件的未加工表面，应涂防锈油，涂油后应涂防锈漆。
53. 装配时各零件的未加工表面，应涂防锈油，涂油后应涂防锈漆。
54. 装配时各零件的未加工表面，应涂防锈油，涂油后应涂防锈漆。
55. 装配时各零件的未加工表面，应涂防锈油，涂油后应涂防锈漆。
56. 装配时各零件的未加工表面，应涂防锈油，涂油后应涂防锈漆。
57. 装配时各零件的未加工表面，应涂防锈油，涂油后应涂防锈漆。
58. 装配时各零件的未加工表面，应涂防锈油，涂油后应涂防锈漆。
59. 装配时各零件的未加工表面，应涂防锈油，涂油后应涂防锈漆。
60. 装配时各零件的未加工表面，应涂防锈油，涂油后应涂防锈漆。
61. 装配时各零件的未加工表面，应涂防锈油，涂油后应涂防锈漆。
62. 装配时各零件的未加工表面，应涂防锈油，涂油后应涂防锈漆。
63. 装配时各零件的未加工表面，应涂防锈油，涂油后应涂防锈漆。
64. 装配时各零件的未加工表面，应涂防锈油，涂油后应涂防锈漆。
65. 装配时各零件的未加工表面，应涂防锈油，涂油后应涂防锈漆。
66. 装配时各零件的未加工表面，应涂防锈油，涂油后应涂防锈漆。
67. 装配时各零件的未加工表面，应涂防锈油，涂油后应涂防锈漆。
68. 装配时各零件的未加工表面，应涂防锈油，涂油后应涂防锈漆。
69. 装配时各零件的未加工表面，应涂防锈油，涂油后应涂防锈漆。
70. 装配时各零件的未加工表面，应涂防锈油，涂油后应涂防锈漆。
71. 装配时各零件的未加工表面，应涂防锈油，涂油后应涂防锈漆。
72. 装配时各零件的未加工表面，应涂防锈油，涂油后应涂防锈漆。
73. 装配时各零件的未加工表面，应涂防锈油，涂油后应涂防锈漆。
74. 装配时各零件的未加工表面，应涂防锈油，涂油后应涂防锈漆。
75. 装配时各零件的未加工表面，应涂防锈油，涂油后应涂防锈漆。
76. 装配时各零件的未加工表面，应涂防锈油，涂油后应涂防锈漆。
77. 装配时各零件的未加工表面，应涂防锈油，涂油后应涂防锈漆。
78. 装配时各零件的未加工表面，应涂防锈油，涂油后应涂防锈漆。
79. 装配时各零件的未加工表面，应涂防锈油，涂油后应涂防锈漆。
80. 装配时各零件的未加工表面，应涂防锈油，涂油后应涂防锈漆。
81. 装配时各零件的未加工表面，应涂防锈油，涂油后应涂防锈漆。
82. 装配时各零件的未加工表面，应涂防锈油，涂油后应涂防锈漆。
83. 装配时各零件的未加工表面，应涂防锈油，涂油后应涂防锈漆。
84. 装配时各零件的未加工表面，应涂防锈油，涂油后应涂防锈漆。
85. 装配时各零件的未加工表面，应涂防锈油，涂油后应涂防锈漆。
86. 装配时各零件的未加工表面，应涂防锈油，涂油后应涂防锈漆。
87. 装配时各零件的未加工表面，应涂防锈油，涂油后应涂防锈漆。
88. 装配时各零件的未加工表面，应涂防锈油，涂油后应涂防锈漆。
89. 装配时各零件的未加工表面，应涂防锈油，涂油后应涂防锈漆。
90. 装配时各零件的未加工表面，应涂防锈油，涂油后应涂防锈漆。
91. 装配时各零件的未加工表面，应涂防锈油，涂油后应涂防锈漆。
92. 装配时各零件的未加工表面，应涂防锈油，涂油后应涂防锈漆。
93. 装配时各零件的未加工表面，应涂防锈油，涂油后应涂防锈漆。
94. 装配时各零件的未加工表面，应涂防锈油，涂油后应涂防锈漆。
95. 装配时各零件的未加工表面，应涂防锈油，涂油后应涂防锈漆。
96. 装配时各零件的未加工表面，应涂防锈油，涂油后应涂防锈漆。
97. 装配时各零件的未加工表面，应涂防锈油，涂油后应涂防锈漆。
98. 装配时各零件的未加工表面，应涂防锈油，涂油后应涂防锈漆。
99. 装配时各零件的未加工表面，应涂防锈油，涂油后应涂防锈漆。
100. 装配时各零件的未加工表面，应涂防锈油，涂油后应涂防锈漆。

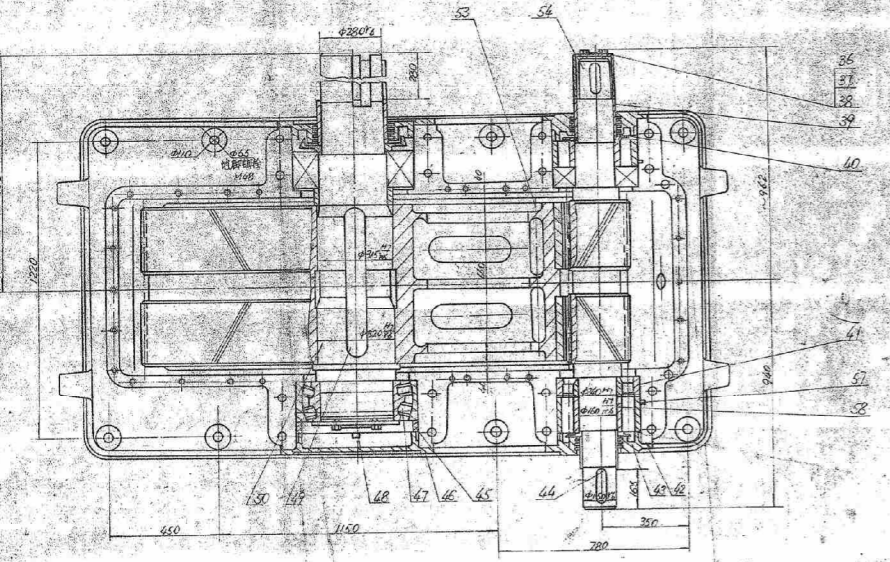

Note
1. Parts (No.12,13,14) are welded with cover.
2. Non-machined surfaces inside the reducer are painted two times with red oil resistant paintings. The non-machined surfaces outside the reducer are painted blue.
3. Reducer minimum backlash is 0.42mm. Enough space is left on the main bearing journal for the mill shell to expand and contract freely.
4. After run-in test, the contact pattern is 70% along tooth lead and 50% along tooth profile.
5. In loaded test, the reducer runs stably for 40 minutes with load under normal temperature. No leakage is found.
6. Name plate is positioned and mounted by the manufacturer.
7. Total weight of the reducer, ratio code 4, excludes the weight of oil pump.
8. In loaded running, the oil temperature in the reducer is less than 45°C above its environmental temperature, while the bearing temperature is less than 50°C above that temperature.
9. Static balance difference of the gear is less than 0.5kg/m.
10. The reducer technical data, after regulated, are filed.
11. The bearings are for forced lubricated.
12. If the assemble code is I, the tooth direction of the gear and the pinion is in reverse as shown in the drawing.
13. If the working direction is in reverse as that shown in the drawing, the tooth direction is as shown in the drawing when assemble code is II. When Code II, it will in the reverse direction.

零件代号	数量	规格	材料	重量
58	1	1100A.25A 油压环	space ring	2 A3 6.67 13.34
57	1	1100A.24B 外圈环	space ring	2 ZD25 15.1 30.2
56	2	WZP-263 固定轴套式油封圈	resistance	2 (Ox)160 0.25 0.5
55	1	1100.60A ZD100B油封圈	oil pump	1 零件 1085 1085
54	1	1100A.23-6 齿轮 mm=10.2=23	shaft gear	1 505mmW (及35CrMo) 468 468 6.1 I 420 420 5.1 I 466 466 6.1 I 543 543 7.1 I 637 637 8.1 I
	1	1100A.23-5 齿轮 mm=10.2=21	"	1 505mmW (及35CrMo) 420 420 5.1 I 466 466 6.1 I 543 543 7.1 I 637 637 8.1 I
	1	1100.23-4A 齿轮 mm=10.2=23	"	1 505mmW (及35CrMo) 468 468 6.1 I 420 420 5.1 I 466 466 6.1 I 543 543 7.1 I 637 637 8.1 I
	1	1100.23-3 齿轮 mm=10.2=21	"	1 505mmW (及35CrMo) 420 420 5.1 I 466 466 6.1 I 543 543 7.1 I 637 637 8.1 I
	1	1100.23-2 齿轮 mm=10.2=29	"	1 505mmW (及35CrMo) 468 468 6.1 I 420 420 5.1 I 466 466 6.1 I 543 543 7.1 I 637 637 8.1 I
	1	1100.23-1A 齿轮 mm=10.2=21	shaft gear	1 505mmW (及35CrMo) 468 468 6.1 I 420 420 5.1 I 466 466 6.1 I 543 543 7.1 I 637 637 8.1 I
	1	1100.50-6 齿轮 mm=10.2=216	gear	1 405mmW (及35CrMo) 3564 3564 6.1 I 4296 4296 5.1 I 4140.6 4140.6 6.1 I 4058 4058 6.1 I 3895 3895 5.1 I 3701.6 3701.6 5.1 I
	1	1100.50-5 齿轮 mm=10.2=150	"	1 405mmW (及35CrMo) 3564 3564 6.1 I 4296 4296 5.1 I 4140.6 4140.6 6.1 I 4058 4058 6.1 I 3895 3895 5.1 I 3701.6 3701.6 5.1 I
	1	1100.50-4A 齿轮 mm=10.2=148	"	1 405mmW (及35CrMo) 3564 3564 6.1 I 4296 4296 5.1 I 4140.6 4140.6 6.1 I 4058 4058 6.1 I 3895 3895 5.1 I 3701.6 3701.6 5.1 I
	1	1100.50-3 齿轮 mm=10.2=145	"	1 405mmW (及35CrMo) 3564 3564 6.1 I 4296 4296 5.1 I 4140.6 4140.6 6.1 I 4058 4058 6.1 I 3895 3895 5.1 I 3701.6 3701.6 5.1 I
	1	1100.50-2 齿轮 mm=10.2=142	"	1 405mmW (及35CrMo) 3564 3564 6.1 I 4296 4296 5.1 I 4140.6 4140.6 6.1 I 4058 4058 6.1 I 3895 3895 5.1 I 3701.6 3701.6 5.1 I
	1	1100.50-1A 齿轮 mm=10.2=140	gear	1 405mmW (及35CrMo) 3564 3564 6.1 I 4296 4296 5.1 I 4140.6 4140.6 6.1 I 4058 4058 6.1 I 3895 3895 5.1 I 3701.6 3701.6 5.1 I

Instruction Manual of Gear Box ZD100B

Tangshan Cement Machinery Works

1997.09.22

226 X 1341 31.00.48

Instruction Manual of Gear Box ZD100B

1. Summary

ZD100, single stage parallel shaft involute cylinder gear box, can be used for all types of ball mills and revent equipments which accord with the working scale of ZD100. As a speed reducing equipment, auxiliary gear box can be equipped to make trail running and adjust the position of the mill man hole. The high speed pinion is a kind of double helical gear with modulus 10mm. One journal of the shaft is connected with the main motor through a rubber coupling and the other end is connected with the auxiliary gear box through a clutch coupling.

The bottom frame of the gear box is a box-shaped cast body and the basin is a steel plate combined parts, which is used for oil basin connected with the bottom frame with bolts. A 2mm thick asbestos-rubber board is used between the basin and the bottom frame to avoid oil leakage. Roller bearings are adopted on the input and output shafts. And pig iron bearing covers are used to fix the bearings tightly. The bearings of the input shaft, which is cylinder roller bearings, can shift axially by themselves to guarantee balancing mesh of the two gears. The double helical gear can be adjusted by itself to control axially movement.

The casing of the gear box is a combined part made of steel plate and is connected with the bottom frame through bolts. Manhole covers and aeration cap on the casing are used to inspect gears' meshing state and letting out hot gas produced during running. Forcing lubrication circuit is for lubricating teeth mesh and bearing, as well as for heat radiation, filtering and circulating with oil tank. And valves and oil flow indicator are used to supply oil and inspect oil flowing state.

Users can install resistance heating system to heat oil when its temperature is below 5°C.

Before installation, the gear box shall be inspected to ensure clean and rustless. If the gear box is stored for a long period, there will be rust and foreign matters in it. Users should clean all the gears, bearings and lubricating circuit etc. fully before its installation.

2. Specification of the Gear Box

No.	Item	Unit	Value
1	equipment		Φ2.6×13m cement mill
2	type		ZD100B-1-I
3	speed ratio		i=4.5
4	assembling type		I
5	center distance	mm	1000
6	permitted power of inlet shaft	kw	1250
7	lubrication form		forcing and splash
8	lubricant brand		N220 medium loaded gear lubricant
9	lubricant standard		GB5903-86
10	lubricant filling quantity	L	580
11	dimension	mm	2790×1410×2540
12	weight	kg	10005
13	motor type		YR1000-8/1180
14	power	kw	1000
15	rated rotating speed	r/min	740
16	voltage	V	6000
17	auxiliary motor type		ZS95-8-I
18	speed ratio		i=110.2

3. Rough Adjustment of the Gear Box

First, position cross should be made according to the marks on the foundation and to the basis reference wire above the mill, on the basis of the installed mill and pinion gear transmission system. Two layers of 0.5mm thick steel sheet shall be placed between bottom frame and base frame just below the four bearings before its positioning. The center height of the gear box should be a little shorter than that of the transmitting shaft in order to increase the height of the gear box during finish adjustment. Engineering level can be used to measure the center heights. The concentricity of the output coupling and the transmitting shaft coupling, which is limited by 0.25mm, can be measured with steel ruler. Then the correct positions of the main motor and the auxiliary gear box should be

determined with the same method on the basis of the gear box. There is a rubber block coupling between the main gear box and the main motor. The fixed coupling which is on the input shaft end of the gear box should be examined before installation. The casting defect and protrusion on the unmachined surface of the jaw coupling should be cleared off. There should be a gap more than 10mm between the two half coupling so as not to influence the magnetic field center of the main motor. The concentricity of the gear box input shaft and the main motor is also limited by 0.25mm. Grout the anchor bolts after all parts are positioned. Don't make finish adjustment until the concrete sample gets compressive strength of more than 200kg/cm²

4. Finish Adjustment of the Gear Box

After getting the required strength of the concrete, all of the anchor bolts can be pretightened. Then disassemble the input shaft coupling of the gear box from the main motor, run the motor and measure the actual axial displacement of the magnetic field center of the main motor with dial indicator in its running and static state for finish adjustment. Disconnect the output shaft coupling of the gear box too, rotate the input shaft by hand, clean the teeth surface of wheel gear and pinion and wash the box's inside with kerosene. Both of the wheel gear and the pinion can be lifted out and cleaned when necessary. Coat a thin layer of colour paints on teeth flank of the pinion evenly, fill a little lubricant into the four bearings, connect the output shaft coupling, drive the auxiliary gear box to rotate the mill without load, inspect the meshing print, then align the gear box according to schematic drawing I, II, III and IV by stuffing copper or steel sheet under the bottom frame. Repeat above process until teeth meshing can meet with drawings' notes. Transparent tape shall be used to take out mesh print from the gear flank, which can be a reference meshing print to compare later. In order to keep the correct height of the input and output shaft ends, the adjustment shall be made on the other two position of the bottom frame below the bearings. The anchor bolts must be tightened firmly to get correct meshing state.

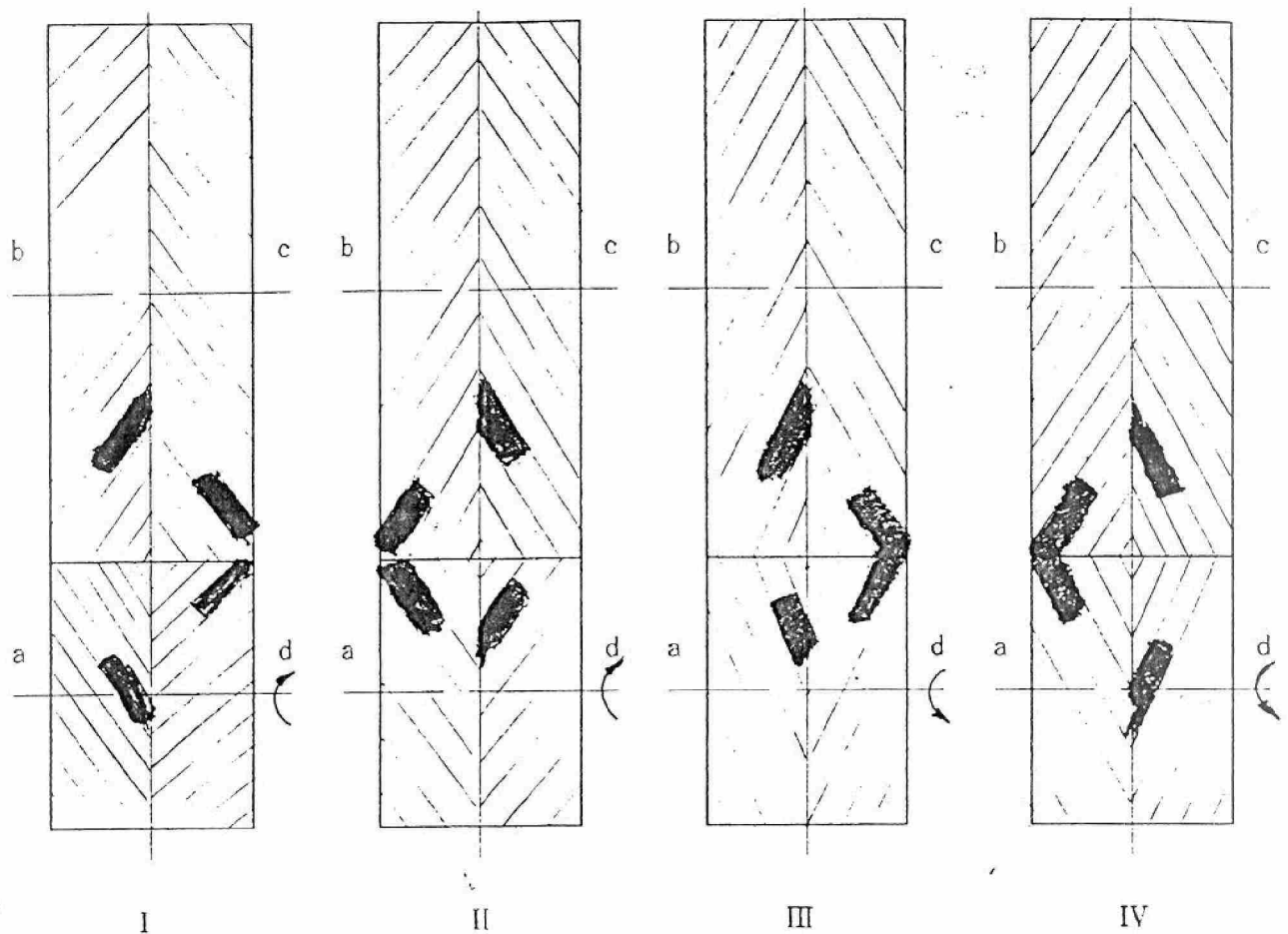

If teeth contact print is as drawing I or IV, shaft end d should be lifted up.
 If teeth contact print is as drawing II or III, shaft end a should be lifted up.

LEVEL ALIGNMENT SCHEMATIC DRAWING

Because the two bearings on the input shaft of ZD-100B gear box are cylinder roller bearings, they can aligned themselves slightly if there isn't influence from outside. And influence must be eliminated if there is any. After teeth flank contact alignment, disconnect the couplings on the input and output shaft. Align the concentricity and axial position of the transmission shaft coupling with dial indicator round its out diameter and on its end surface. The variety of the magnetic field center of the motor should be considered. Concentricity and end output is limited by 0.1mm. Trial running can be taken after the finish alignment of the main gear box and main motor.

5. Trial Running of the Gear Box

- 1) First add N220 medium loaded gear lubricant into oil basins of the gear box and the lubricating station until it reaches the oil level mark.
- 2) Then start the forcing lubricating pump, inspect whether oil supply is normal and whether oil is distributed on all the lubricating areas.
- 3) Start time of the main motor should be more than 16 seconds in order that the maximum start torsion of the gear box won't be more than 2.4 times of the running power.
- 4) Trial time and requirement
 - A. The main motor should run for 0.5 hour without any load,
 - B. run for 24 hours with 30% of full loads,
 - C. run for 72 hours with 60% of full loads,
 - D. run for 120 hours with 80% of full loads,
 - E. and run for 200 hours with full loads. Then trial running is completed.
- 5) The followings should be inspected during trial running.
 - A. Is oil supply of all circuits is normal or not?
 - B. Is teeth flank is smooth or not?
 - C. Is running noise of the gear box well distributed or not? Is there any periodic impacting noise or not? What about vibration?
 - D. The temperature rising of the gear box oil basin shall not be more than 40°C above the environment temperature. The temperature rising of bearings shall be 45°C, maximizing no more than 80°C. If too high oil temperature rising is found out, trouble shooting is needed.
 - E. Is there any leakage in any part of the gear box?

6. Maintenance and Operation of the Gear Box

- 1) The gear box must be operated according to this instruction manual.
- 2) Contrary rotation is not permitted.
- 3) Use the specified lubricant. If other lubricant would be used, its viscosity, impurity and moisture content should be chemical analysed to guarantee its required quantity index.
- 4) Change the lubricant when the machine has run for the first six months. Later changings of lubricant can be determined by the result of chemical analysis, which should be made one or two times every year.

- 5) During the gear box's running, check its noise, vibration and temperature rising whenever necessary. If there is any trouble, find out causes and solve the problems.
- 6) Inspect the working surface of the gears regularly. If there is any critical wear or scratch, find out causes and solve the problem. When pitting area, which appears during the early operating days and expands very slowly, is no more than 20% of the total working area, the gear box can be used continuously. But inspection shall be strengthened. If it expands very fast, users should find out causes and notify the manufacturer. Make a record of regular inspection result in order to analyse and compare with each other to avoid breakdown.
- 7) The out surface of the machine should be kept clean so as to ensure heat radiation.
- 8) Please refer to attached drawings for the operation of the lubrication system.

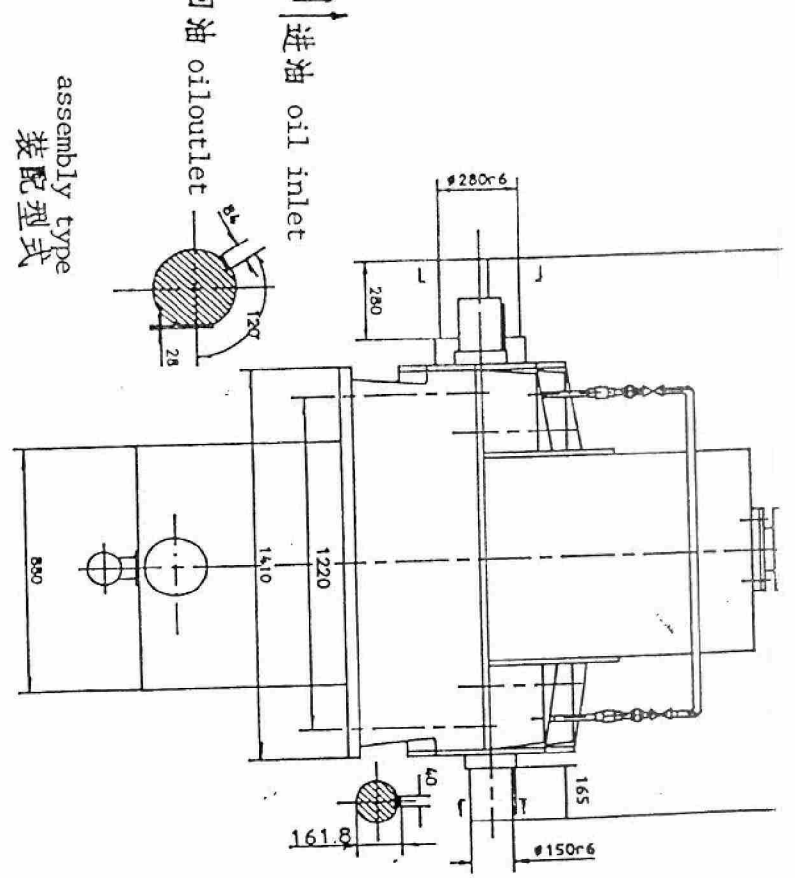
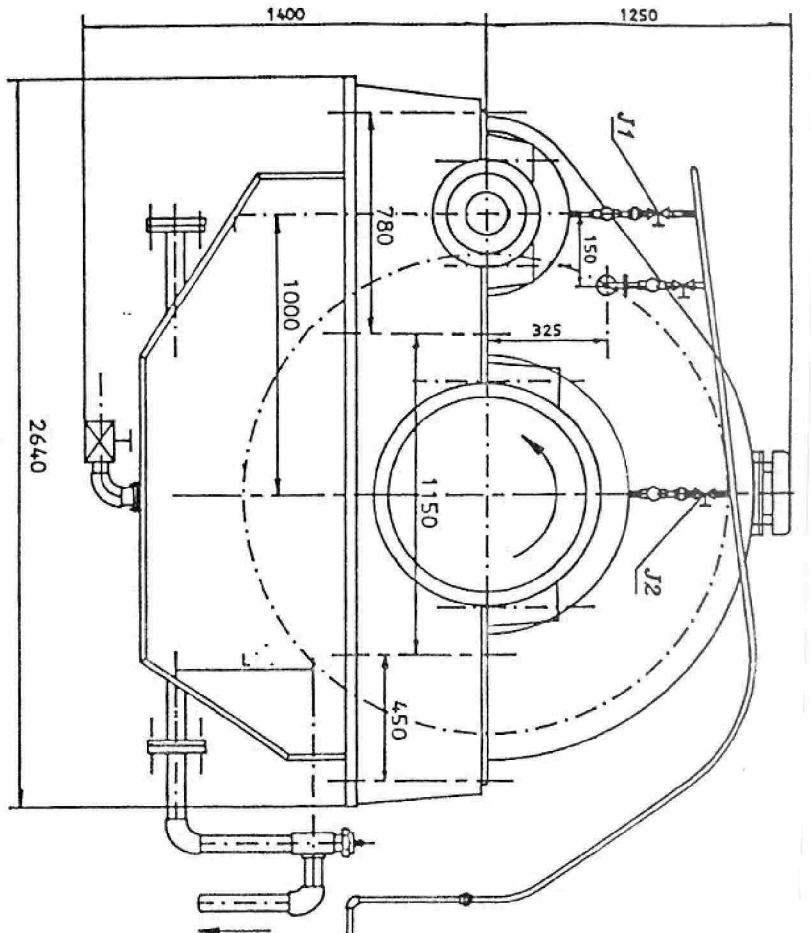

Note

1. Regulate valves J1, J2 to maintain the oil level.
2. 40 holes/inch copper strainer is usable.
3. Reducer is 2m higher than the oil return duct of the oil pump.

技术要求

1. 图中 J1, J2 接口应适当调整, 以指示器有油流下即可以免外溢.
2. 用户可以将稀油站中回油过滤网换成 40 目/吋的钢丝网.
3. 减速机与稀油站回油口之高度差应大于两米.

速比代号	L (mm)
1	440
2	430
3	410
4	395
5	383
6	375

〈附图〉 ZD100B 减速机总布置图

reducer arrangement

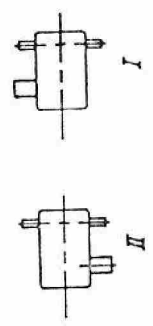

assembly type
装配型式

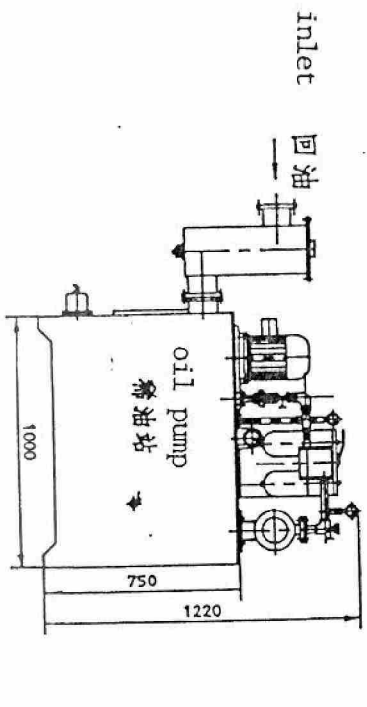

Instruction Manual of Gear Box ZD100B

Tangshan Cement Machinery Works

1997.09.22

31... 1997.09.22

2. Specification of the Gear Box

No.	Item	Unit	Value
1	equipment		$\Phi 2.6 \times 13m$ cement mill
2	type		ZD100B-1-I
3	speed ratio		$i=4.5$
4	assembling type		I
5	center distance	mm	1000
6	permitted power of inlet shaft	kw	1250
7	lubrication form		forcing and splash
8	lubricant brand		N220 medium loaded gear lubricant
9	lubricant standard		GB5903-86
10	lubricant filling quantity	L	580
11	dimension	mm	$2790 \times 1410 \times 2540$
12	weight	kg	10005
13	motor type		YR1000-8/1180
14	power	kw	1000
15	rated rotating speed	r/min	740
16	voltage	V	6000
17	auxiliary motor type		ZS95-8-I
18	speed ratio		$i=110.2$

3. Rough Adjustment of the Gear Box

First, position cross should be made according to the marks on the foundation and to the basis reference wire above the mill, on the basis of the installed mill and pinion gear transmission system. Two layers of 0.5mm thick steel sheet shall be placed between bottom frame and base frame just below the four bearings before its positioning. The center height of the gear box should be a little shorter than that of the transmitting shaft in order to increase the height of the gear box during finish adjustment. Engineering level can be used to measure the center heights. The concentricity of the output coupling and the transmitting shaft coupling, which is limited by 0.25mm, can be measured with steel ruler. Then the correct positions of the main motor and the auxiliary gear box should be

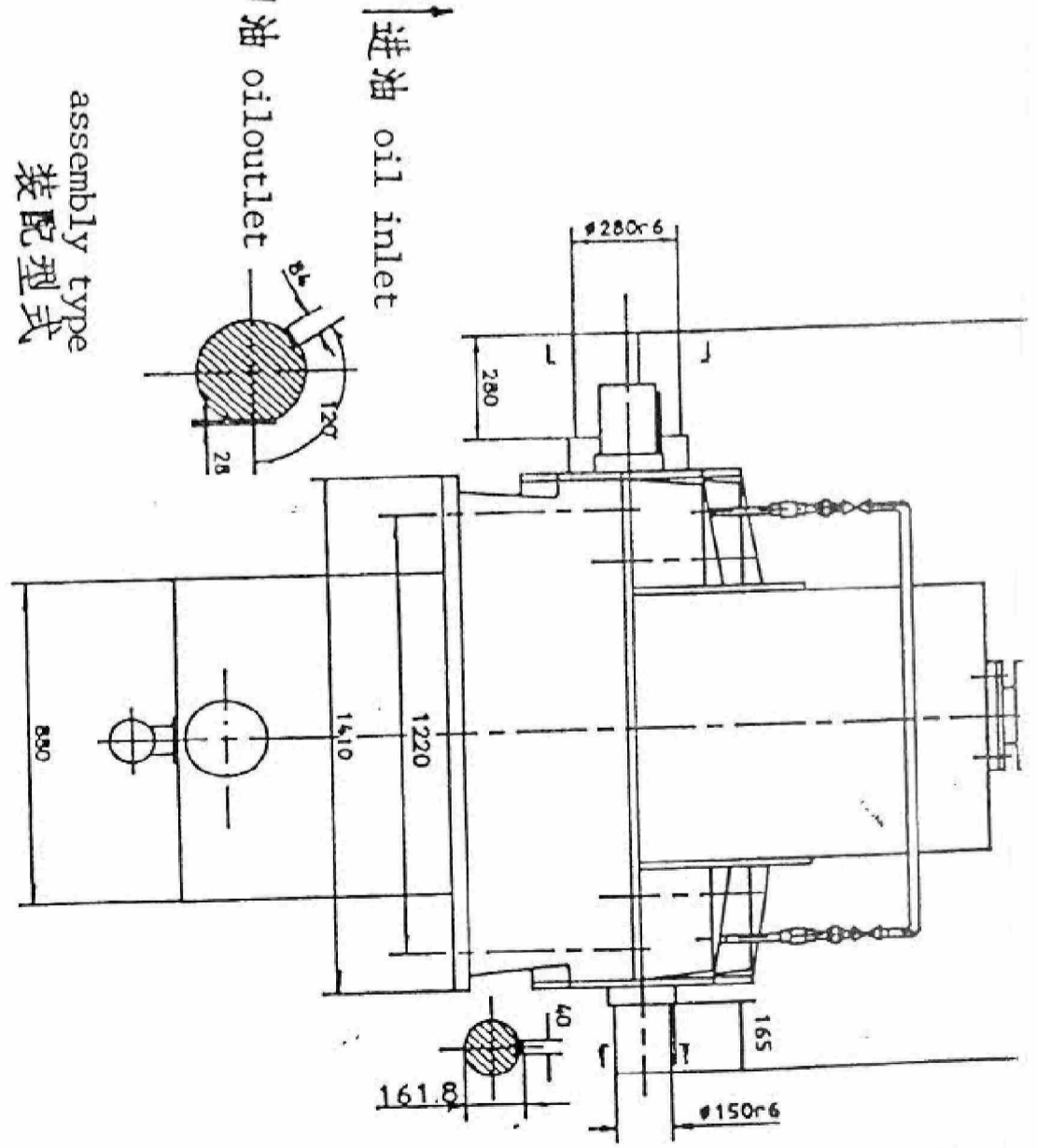
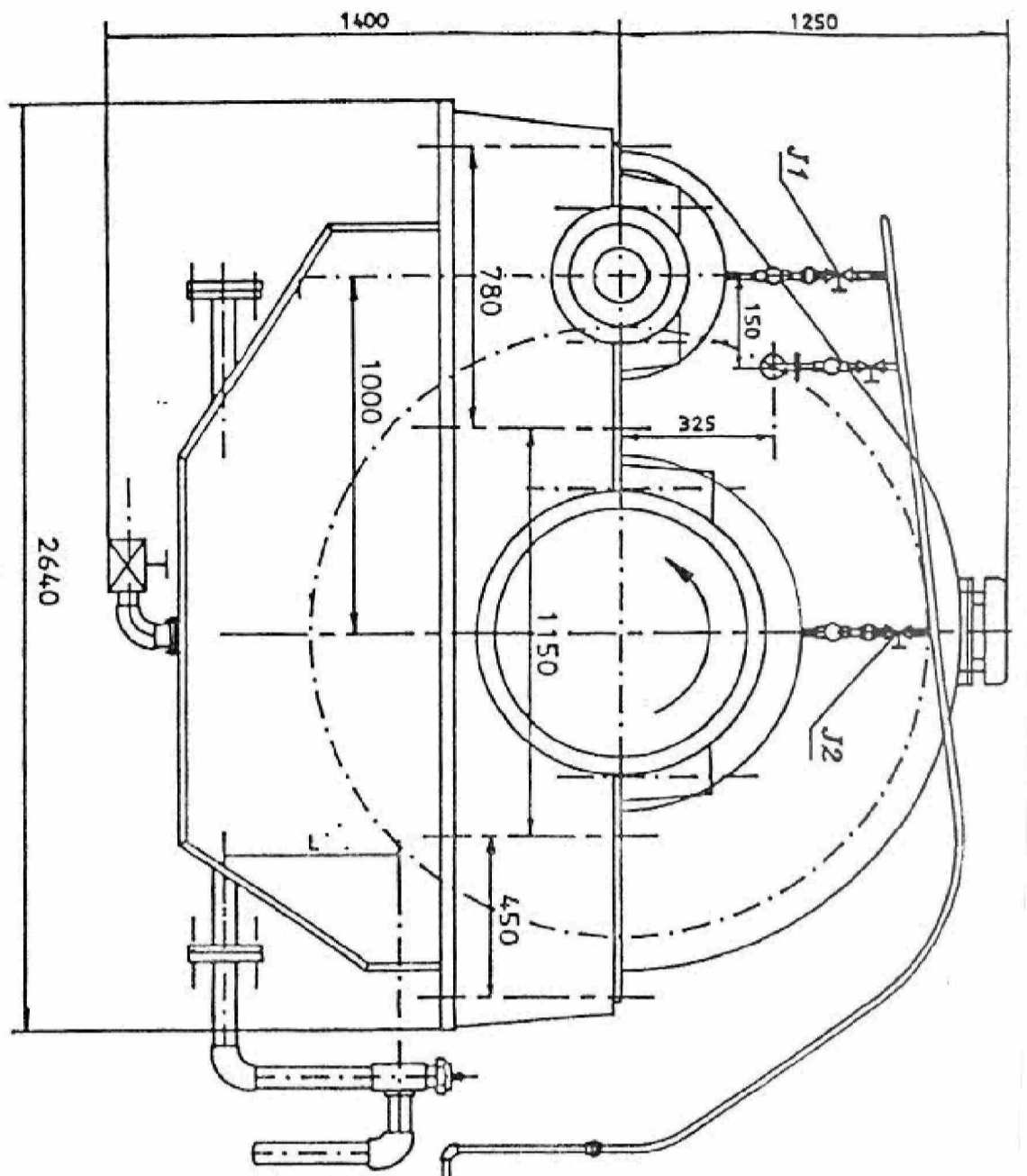

Note

1. Regulate valves J1, J2 to maintain the oil level.
2. 40 holes/inch copper strainer is usable.
3. Reducer is 2m higher than the oil return duct of the oil pump.

技术要求

1. 图中J1, J2阀门应当调整, 以指示器有油流下即可以免外溢.
2. 用户可以将稀油站中回油过滤网换成40目/吋的钢丝网.
3. 减速机与稀油站回油口之高度差应大于两米.

速比代号	L (mm)
1	440
2	430
3	410
4	395
5	383
6	375

assembly type
装配型式

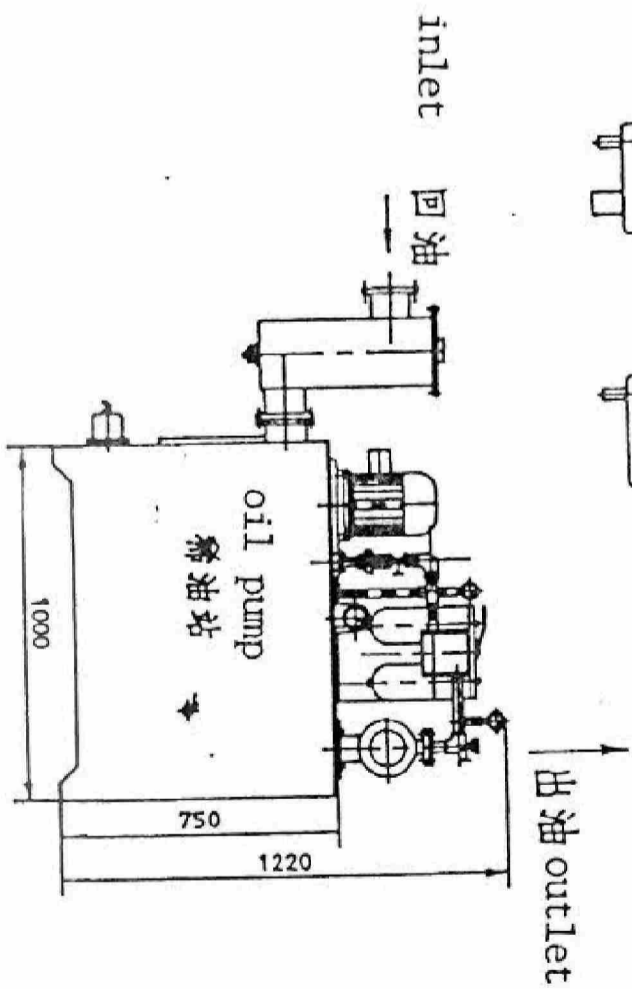
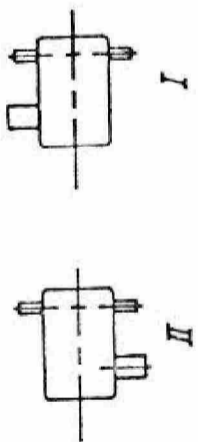

附图) ZD100B 减速机总布置图

reducer arrangement

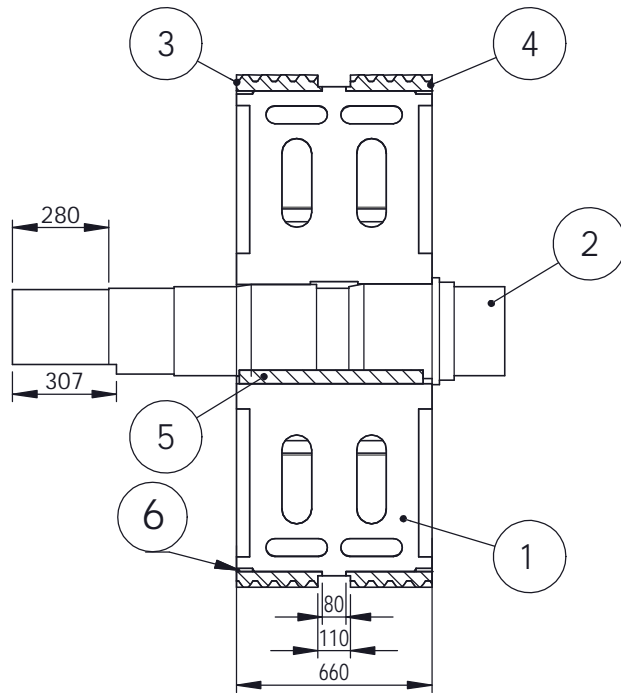
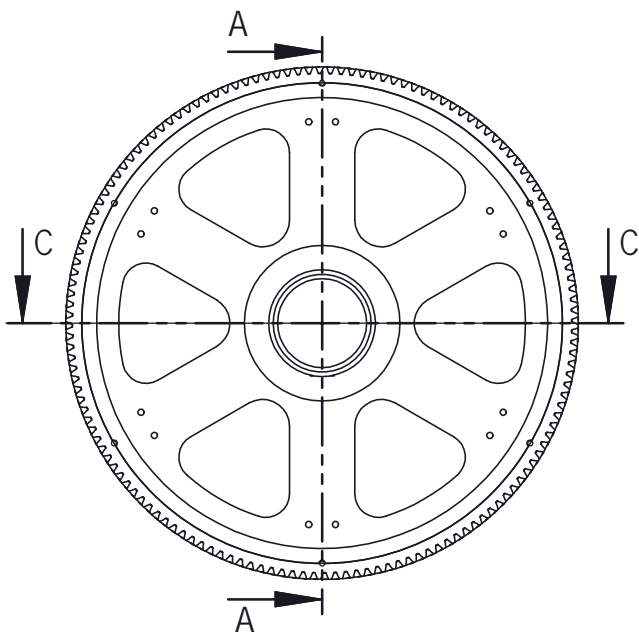

SECTION A-A
SCALE 1 : 25

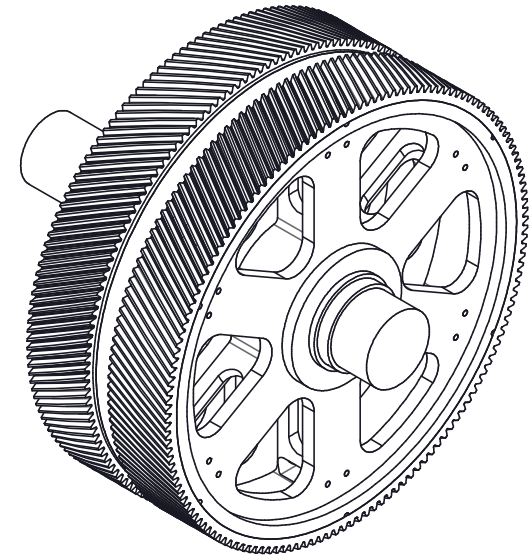

توجه:
هنگام جا زدن دنده ها بر روی نافی دقت شود که دنده راست
سمت قطر 320 و دنده چپ سمت قطر 315 جا زده شود

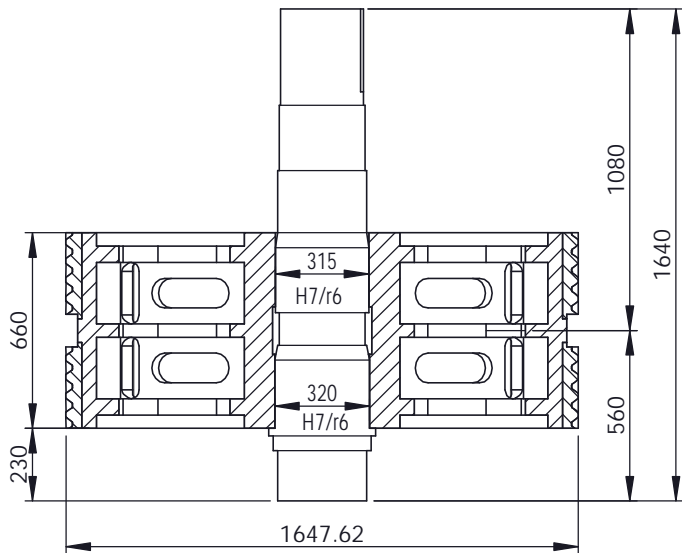

SECTION C-C
SCALE 1 : 25

مدول نرمال	mn	10
قطر دایره سر	da	1647.62
قطر دایره گام	d	1627.62
قطر دایره پا	df	1602.62
تعداد دندانه	z	140
زاویه دندانه	B	30°:40'
نوع دندانه	Type	LH,RH

6	Bolt M24*2*54	12	MO40		2.5 kg
5	Key (70*36*600)	1	CK45		12 kg
4	RH Helical Gear	1	16582		490 kg
3	LH Helical Gear	1	16582		490 kg
2	Shaft	1	MO40		880 kg
1	Hub	1	GGG50		3173kg
No.	Name	Qty	Material	Drawing No	Weight(kg)

Notes:
1.All Dimensions In mm.
2.The Other Tolerances Are DIN 7168 T2(7.86).
3.Surface Finish:

YASUJ CEMENT
COMPANY

Name		TITLE: دنده جناغی گیربکس اصلی آسیاب سیمان			
Drawn	J.Behrouzpoor	Hub of ZD100B-4I Reducer			
Design	_____				
Check	A.h.Ahmadi	DWG NO.	ACC.to: 08.13/14	Sheet:	
Approve	Kh.Nikbakht	Revision: 0	Date: 23.05.95	1/5	
WEIGHT:	5048 kg	SCALE:1:50	Warehouse No:	A4	

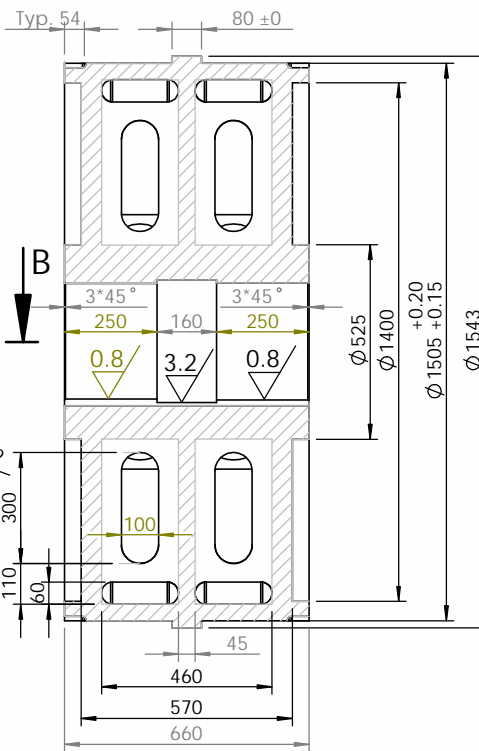
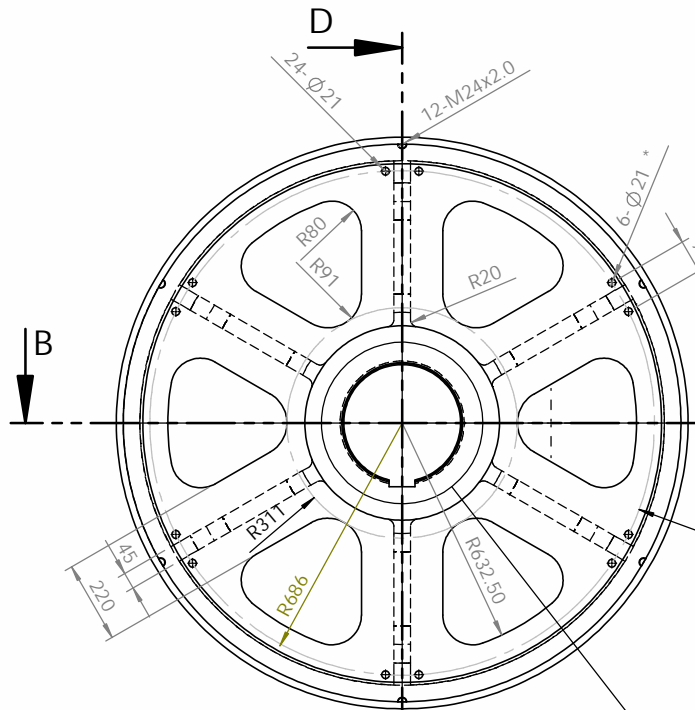

SECTION D-D
SCALE 1 : 20

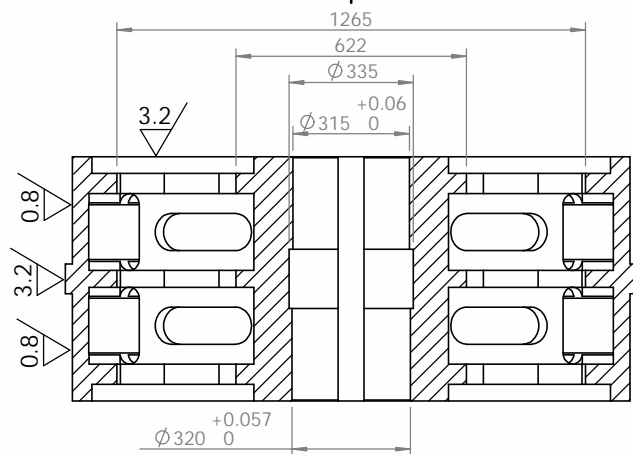
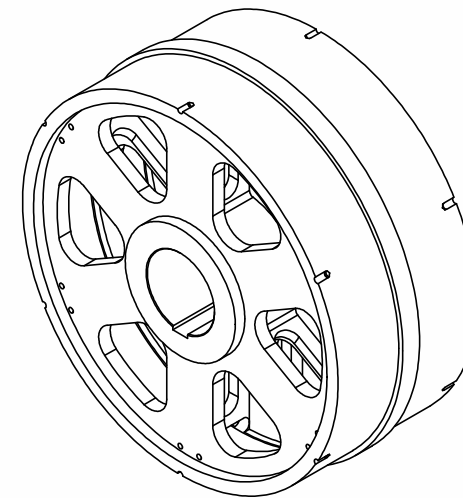

SECTION B-B
SCALE 1 : 20

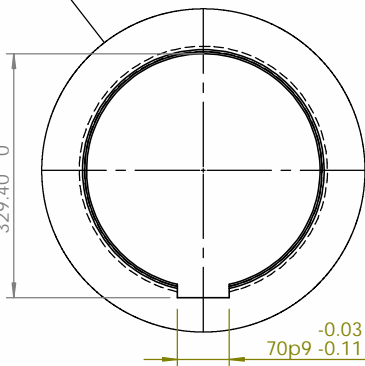

DETAIL F
SCALE 1 : 10

توجه:
* سوراخکاری ها با مته انجام شود *

- Notes:
1.All Dimensions In mm.
2.The Other Tolerances Are DIN 7168 T2(7.86).
3.Surface Finish: $\sqrt{3.2/0.8}$

**YASUJ CEMENT
COMPANY**



Name	TITLE: نافی دنده ی بزرگ گیربکس اصلی آسیاب سیمان		
Drawn	J.Behrouzpoor		
Design			
Check	A.h.Ahmadi		
Approve	Kh.Nikbakht		
MATERIAL:	GGG50	DWG NO.	ACC.to:08.13&14
		Revision: 0	Date: 15.04.95
			Sheet: 2/5
WEIGHT:	SCALE:1:50	Warehouse No:	A4

A

B

C

D

A

B

C

D

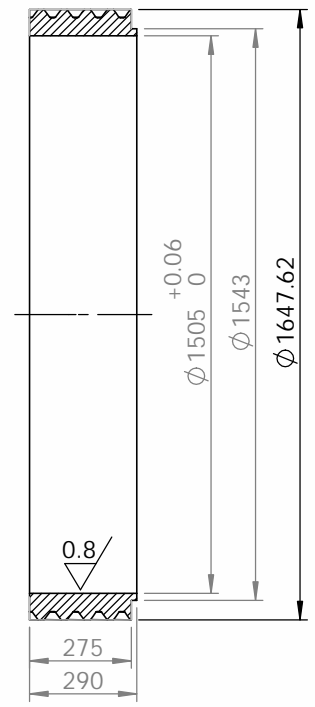
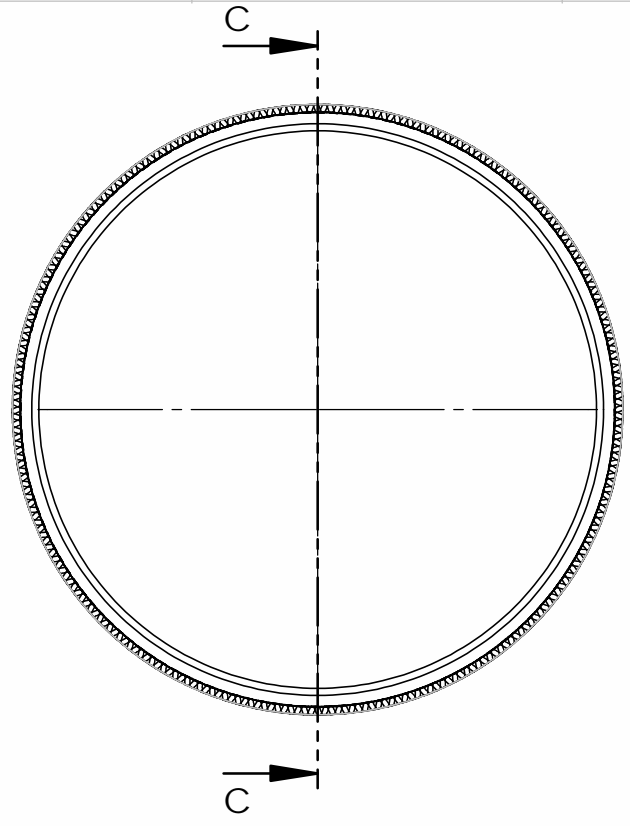

SECTION C-C

فاصله محور تا محور	a	1000
مدول نرمال	mn	10
قطر دایره سر	da	1647.62
قطر دایره گام	d	1627.62
قطر دایره پا	df	1602.62
تعداد دندانه	Z	140
زاویه دندانه	B	30°:40'
نوع دندانه	Type	LH

Notes:
 1.All Dimensions In mm.
 2.The Other Tolerances Are DIN 7168 T2(7.86).
 3.Surface Finish: $\frac{3.2}{\sqrt{\quad}} / \frac{0.8}{(\sqrt{\quad})}$

YASUJ CEMENT COMPANY



Name		TITLE:		
Drawn	J.Behrouzpoor	دنده ی سمت چپ،دنده ی بزرگ گیربکس آسیاب سیمان		
Design		LH of Helical Gear of ZD100B-4I Reducer		
Check	A.h.Ahmadi			
Approve	Kh.Nikbakht			
MATERIAL: 1.6582		DWG NO.	ACC.to: 08.13&14	Sheet: 3/5
		Revision: 0	Date: 24.04.95	A4
WEIGHT:		SCALE:1:20	Warehouse No:	

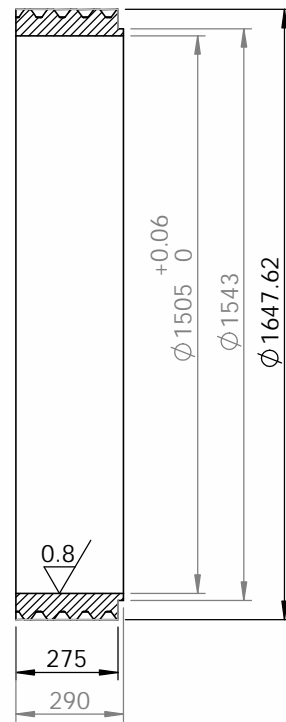
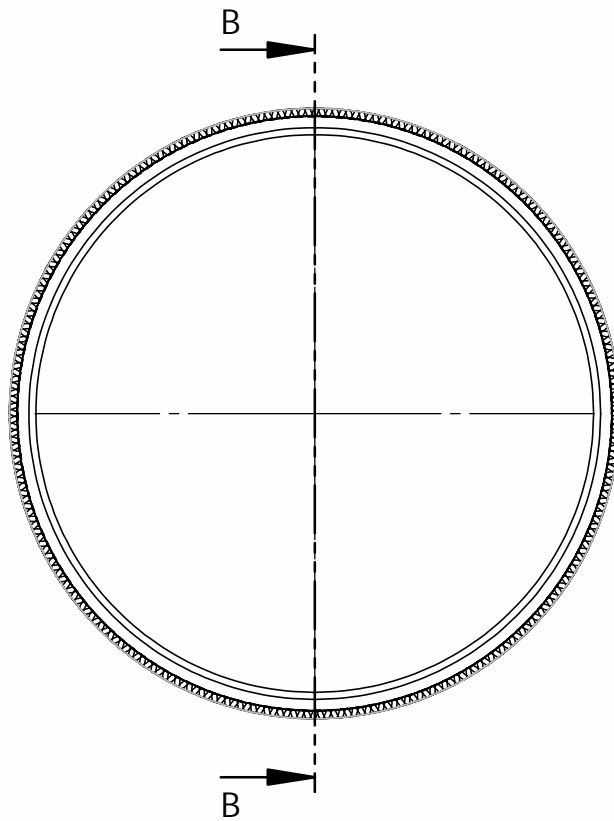

SECTION B-B

فاصله محورتا محور	a	1000
مدول نرمال	mn	10
قطر دایره سر	da	1647.62
قطر دایره گام	d	1627.62
قطر دایره پا	df	1602.62
تعداد دندانه	Z	140
زاویه دندانه	B	30°:40'
نوع دندانه	Type	RH

- Notes:
 1.All Dimensions In mm.
 2.The Other Tolerances Are DIN 7168 T2(7.86).
 3.Surface Finish: $\sqrt{3.2}$ / $\sqrt{0.8}$

YASUJ CEMENT COMPANY



Name	TITLE:	
Drawn	J.Behrouzpoor	دنده ی سمت راست،دنده ی بزرگ گیربکس آسیاب سیمان RH of Helical Gear of ZD100B-4I Reducer
Design		
Check	A.h.Ahmadi	
Approve	Kh.Nikbakht	
MATERIAL: 1.6582	DWG NO.	ACC.to: 08.13&14
	Revision: 0	Date: 24.04.95
		Sheet: 4/5
		A4
WEIGHT:	SCALE:1:20	Warehouse No:

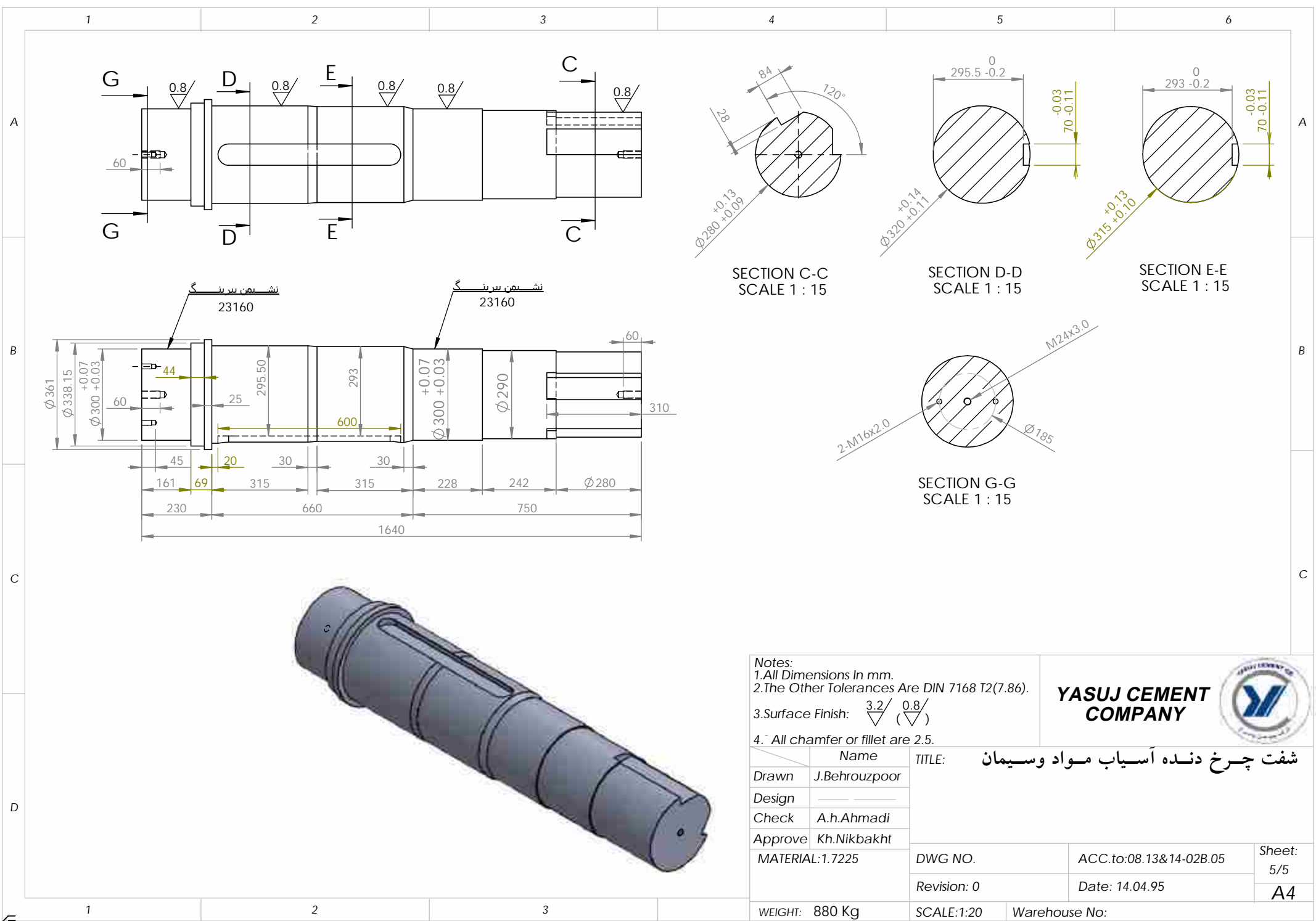

- Notes:
 1. All Dimensions In mm.
 2. The Other Tolerances Are DIN 7168 T2(7.86).
 3. Surface Finish: $\sqrt{3.2}$ / $\sqrt{0.8}$
 4. All chamfer or fillet are 2.5.

YASUJ CEMENT COMPANY



شفٹ چرخ دنده آسیاب مواد وسیمان

Name	J.Behrouzpoor
Design	
Check	A.h.Ahmadi
Approve	Kh.Nikbakht

TITLE:	شفٹ چرخ دنده آسیاب مواد وسیمان	
DWG NO.	ACC.to:08.13&14-02B.05	Sheet: 5/5
Revision: 0	Date: 14.04.95	A4

WEIGHT: 880 Kg	SCALE:1:20	Warehouse No:
----------------	------------	---------------

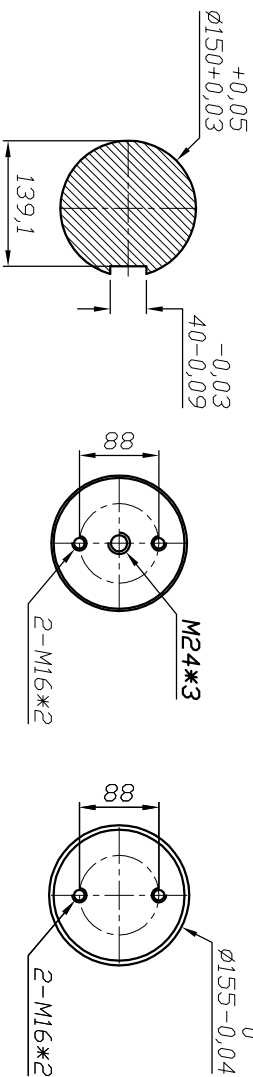
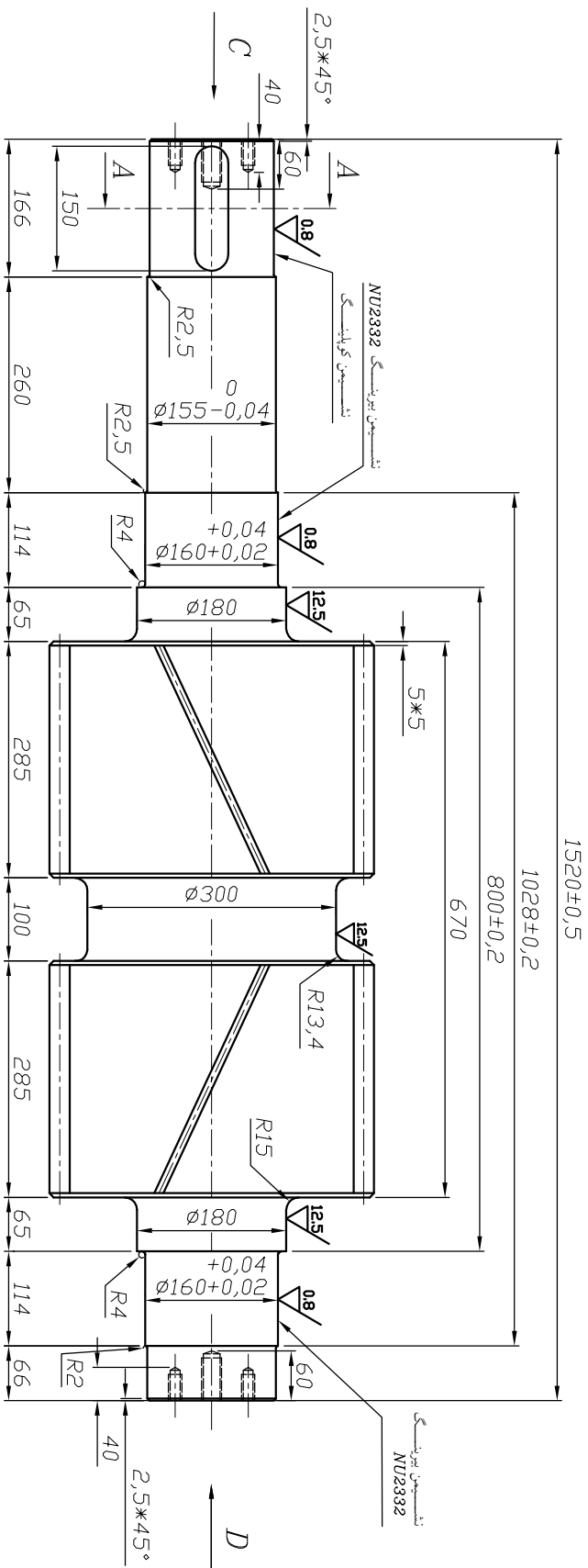

توجه:

۱. تمامی ابعاد بر حسب میلی متر می باشد -
۲. تolerانس سایر اندازه ها طبق نرم (DIN 7168 T2) می باشد -
۳. کیفیت سطح - $\sqrt{0,8}$ ($\sqrt{1,25}$) $\sqrt{3,2}$

Test Dimension	K=6	173.05
	K=7	172.85 202.52 202.47
Correction	x	0.62
فاصله سرک تا سرک	α	1000
زاویه فشار	α	10°
زاویه مسارچ	β	$30^\circ \pm 0,0$
سختی	HRC	۳۲-۳۴
نوع چرخ دنده		دندانه مایل دویل
نوع دنده ها		دنده چپ و راست
مدول نرمال	mm	10
تعداد دنده ها	Z1	31
	Z2	31
قطر دایره پای دنده	df	347.4
قطر خارجی	da	392.3 -0.1

YASUJ
CEMENT COMPANY



Rev: 5	Date: 98.04.31	Checked By: A.H.Ahmadadi
Drawn By: J.Behrouzpoor	Design By:	Approved By: Kh.Nikbakht
Code: 521-22-11-124	Material: (1.6582) VCN150	
Scale: N.T.S	PART No: پینتورن گ کبریکس اصلی آسیاب سیمان (شفت مرحله اول)	
	Weight kg	
	Drawing No:	
	Page: 1/1	